



First choice when
quality counts.™

Husky™ 515 / 716 Air-Operated Diaphragm Pumps



515 – Acetal



515 – Polypropylene



515 – Kynar



716 – Aluminum



716 – 316 SST

- **515 – 1/2 in. non-metallic pumps in acetal, polypropylene, and kynar**
- **716 – 3/4 in. metal pumps in SST, aluminum**
- **No seals to leak or fail mean less downtime**
- **Clean, hands-off fluid handling**
- **Quiet running, less than 85 dB(A) with easy to use remote muffler capability for even lower noise levels**
- **High flow rates in a small portable package**

**Reliable
transfer pump
handles
a variety
of fluids**

Multiple Uses and Hard Working

The Husky 515/716 is a versatile pump, well suited for a variety of utility duties requiring operation up to 16 gpm (60 lpm) with light to medium viscosity fluids. This is an excellent pump for a variety of applications, including machine lube servicing, cleaning fluids and detergents, plating and dip tanks, water treatment, chemicals and other difficult fluids. Uses include drum evacuation, chemical injection, ceramic glaze supply, low viscosity printing inks and similar fluids. Because of its small size, the Husky 515/716 is compact, lightweight and easy to carry.

The Husky 515 (1/2 in. pump) is available in three models: acetal for solvents and flammables, polypropylene for acids and bases, and kynar for harsh chemicals and hot acids. The 716 (3/4 in. pump) is available in aluminum for oil, water, and most solvents, and stainless steel for those wanting an all metal pump with excellent corrosion and abrasion resistance.

Air Valve Design

The Husky 515/716 now features Graco's patented air valve design with the following advantages.

- Simple design with only 8 parts, accessed by unscrewing the top air inlet cover
- Lubricated air is not required
- Air valve operates with 25 psi (0.17 MPa, 1.7 bar) air or less
- Patented 1040 dual cup air valve design



Technical Specifications for Husky 515/716

Maximum working fluid pressure	100 psi (0.7 MPa, 7 bar)
Air pressure operating range	25-100 psi (0.18 to 0-7 MPa, 1.8 to 7 bar)
Maximum air consumption	28 scfm (0.672 m ³ /min.)
Maximum free flow delivery	
For 515	15 gpm (57 lpm)
For 716	16 gpm (61 lpm)
Maximum pump speed	400 cpm
Gallons (liters) per cycle	0.04 gallon (0.15 liter)
Maximum suction lift (water)	
Dry	15 ft. (4.5 m)
Wet	25 ft. (7.6 m)
Maximum size pumpable solids	3/32 in. (2.5 mm)
Sound power level (measured per ISO standard 9614-2)	
At 70 psig (0.48 MPa, 4.8 bar) at 50 cpm	77 dBa
At 100 psig (0.7 MPa, 7 bar) at maximum cpm	95 dBa
Sound pressure level (measured 1 meter from pump)	
At 70 psig (0.48 MPa, 4.8 bar) at 50 cpm	67 dBa
At 100 psig (0.7 MPa, 7 bar) at maximum cpm	85 dBa
Air inlet size	1/4 npt(f)
Air exhaust port size	3/8 npt(f)
Fluid inlet size	
For 515	1/2 and 3/4 npt(f) or bspt(f)
For 716	3/4 npt(f) or bspt(f)
Fluid outlet size	
For 515	1/2 and 3/4 npt(f) or bspt(f)
For 716	3/4 npt(f) or bspt(f)
Wetted parts (in addition to ball, seat, and diaphragm materials, which may vary by pump)	
Acetal pumps	groundable acetal, Teflon®
Polypropylene pumps	polypropylene, Teflon
Kynar pumps	Kynar, Teflon
Aluminum pumps	aluminum, SST, Teflon, zinc-plated steel
SST pumps	polypropylene, SST, polyester (labels), nickel-plated brass, epoxy-coated steel (feet)
Weight	
Acetal pumps	7.8 lbs. (3.5 kg)
Polypropylene pumps	6.5 lbs. (2.9 kg)
Kynar pumps	8.5 lbs. (3.9 kg)
Aluminum pumps	8.5 lbs. (3.9 kg)
SST pumps	18 lbs. (8.2 kg)
Instruction manual	308981

Kynar® is a registered trademark of Atochem North America, Incorporated.

Teflon® is a registered trademark of Du Pont.

Husky 515/716 Pump Performance

Fluid Pressure

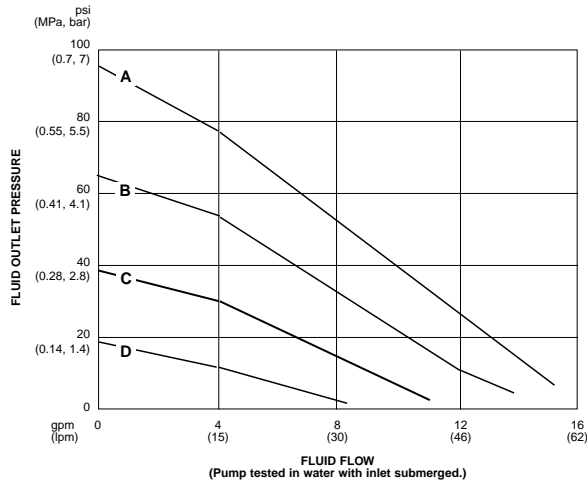

Air Consumption

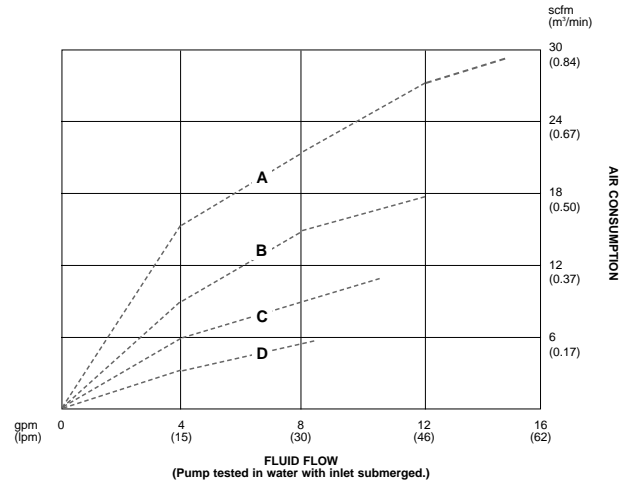

Key:
 — Fluid Outlet Pressure
 - - - - - Air Consumption

Air Pressures:
 A = at 100 psi (0.7 MPa, 7 bar)
 B = at 70 psi (0.48 MPa, 4.8 bar)
 C = at 40 psi (0.28 MPa, 2.8 bar)
 D = at 20 psi (0.14 MPa, 1.4 bar)

Kits for Husky 515/716

241405 Proximity Switch Kit

Includes the reed switch and magnet.

241406 Counter Kit

Includes the reed switch, magnet, battery-operated counter with mounting bracket.

241657 Air Valve Repair Kit

Split Manifold Kit for 515

- 241243 Polypropylene, top
- 241240 Polypropylene, bottom
- 241244 Acetal, top
- 241241 Acetal, bottom
- 241245 Kynar, top
- 241242 Kynar, bottom

238084 Evacuation Air Restrictor Kit

221094 Suction Kit

55 gallon (200 liter), bung mount, SST. For more information, see Husky Diaphragm Pump Suction Kits (Form No. 300-450).

221095 Pail Mount Kit

5 gallon (20 liter). Includes cover, suction tube and hardware.

241262 Duckbill Replacement Kit

Includes 4 valves and 4 spacers.

Air Motor Retrofit

Turn any existing 715 metal pump into the new 716 by buying an air motor Retrofit Kit.

241631 Air Motor Retrofit

241664 Remote-Controlled Air Motor Retrofit



Air Motor Retrofit

Husky 515 Dimensions

515 Plastic Models

Front View

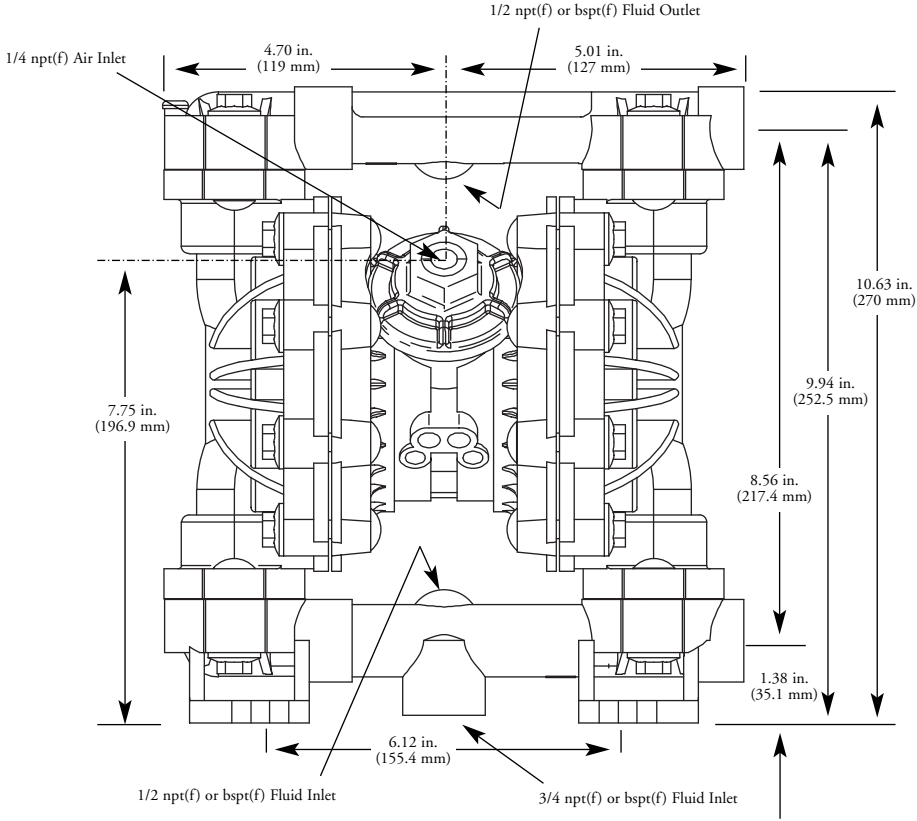

Side View

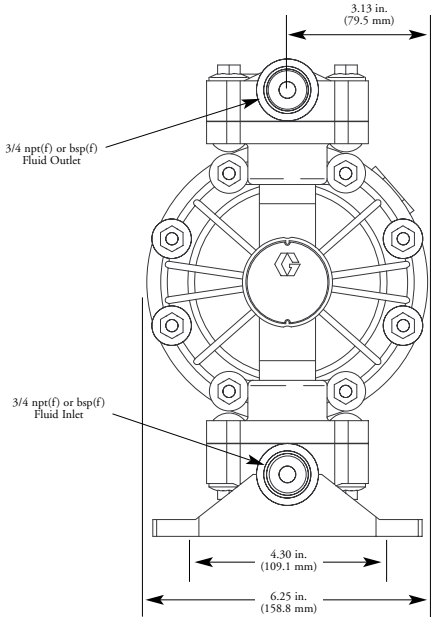

Mounting Hole Pattern for 515 Plastic Models:

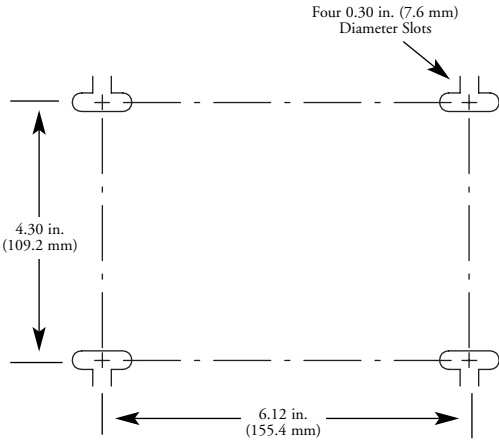

Husky 716 Dimensions

716 Metal Models

Front View

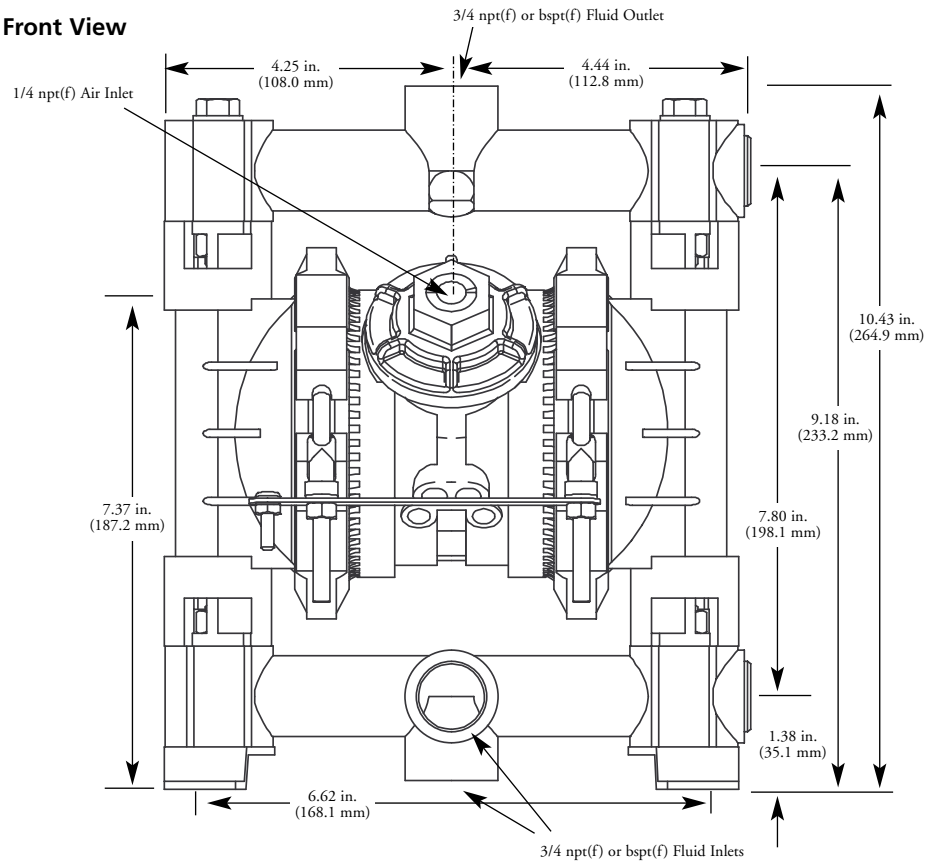

Side View

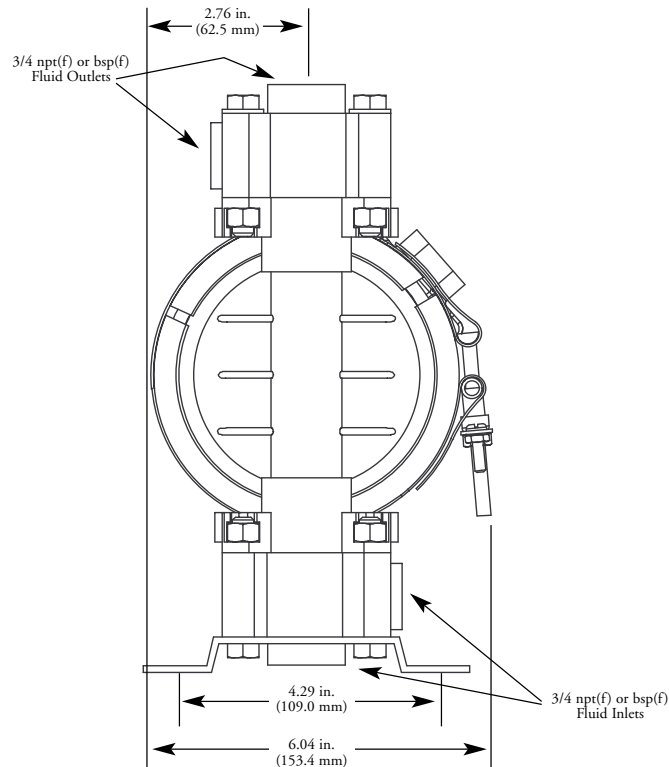

Mounting Hole Pattern for 716 Metal Models:

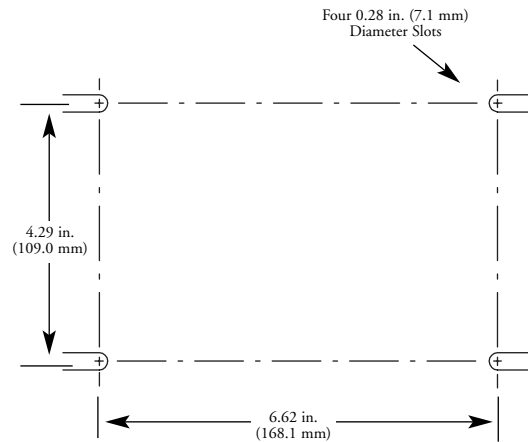

Order Numbers for the Husky 515

Part No.	Remote-Controlled Part No.	Model	Fluid	Seat	Ball	Diaphragm	Service Kits Part No.
D51211	D41211	515	Acetal	Acetal	TF	TF	D05211
D51231	D41231	515	Acetal	Acetal	SST	TF	D05231
D51255	D41255	515	Acetal	Acetal	HY	HY	D05255
D51266	D41266	515	Acetal	Acetal	SP	SP	D05266
D51275	D41275	515	Acetal	Acetal	BN	HY	D05275
D51277	D41277	515	Acetal	Acetal	BN	BN	D05277
D51311	D41311	515	Acetal	SST	TF	TF	D05311
D51331	D41331	515	Acetal	SST	SST	TF	D05331
D51911	D41911	515	Acetal	PP	TF	TF	D05911
D51977	D41977	515	Acetal	PP	BN	BN	D05977
D51D05	D41D05	515	Acetal	Duckbill	None	HY	D05D05
D51D06	D41D06	515	Acetal	Duckbill	None	SP	D05D06
D51D07	D41D07	515	Acetal	Duckbill	None	BN	D05D07
D52211	D42211	515	PP	Acetal	TF	TF	D05211
D52277	D42277	515	PP	Acetal	BN	BN	D05277
D52311	D42311	515	PP	SST	TF	TF	D05311
D52331	D42331	515	PP	SST	SST	TF	D05331
D52336	D42336	515	PP	SST	SST	SP	D05336
D52911	D42911	515	PP	PP	TF	TF	D05911
D52915	D42915	515	PP	PP	TF	HY	D05915
D52916	D42916	515	PP	PP	TF	SP	D05916
D52918	D42918	515	PP	PP	TF	VT	D05918
D52931	D42931	515	PP	PP	SST	TF	D05931
D52937	D42937	515	PP	PP	SST	BN	D05937
D52955	D42955	515	PP	PP	HY	HY	D05955
D52961	D42961	515	PP	PP	SP	TF	D05961
D52966	D42966	515	PP	PP	SP	SP	D05966
D52977	D42977	515	PP	PP	BN	BN	D05977
D52988	D42988	515	PP	PP	VT	VT	D05988
D52D05	D42D05	515	PP	Duckbill	None	HY	D05D05
D52D06	D42D06	515	PP	Duckbill	None	SP	D05D06
D52D07	D42D07	515	PP	Duckbill	None	BN	D05D07
D55A11	D45A11	515	KY	KY	TF	TF	D05A11
D55A88	D45A88	515	KY	KY	VT	VT	D05A88
241564*	NA	515	Acetal	Acetal	TF	TF	D05211
241565**	NA	515	Poly	Poly	TF	TF	D05911

* open down ports (pump equivalent to D51211)

** open down ports (pump equivalent to D52911)

Order Numbers for the Husky 716

Part No.	Remote-Controlled Part No.	Model	Fluid	Seat	Ball	Diaphragm	Service Kits Part No.
D53211	D43211	716	Alum	Acetal	TF	TF	D05211
D53215	D43215	716	Alum	Acetal	TF	HY	D05215
D53231	D43231	716	Alum	Acetal	SST	TF	D05231
D53237	D43237	716	Alum	Acetal	SST	BN	D05237
D53255	D43255	716	Alum	Acetal	HY	HY	D05255
D53266	D43266	716	Alum	Acetal	SP	SP	D05266
D53277	D43277	716	Alum	Acetal	BN	BN	D05277
D53288	D43288	716	Alum	Acetal	VT	VT	D05288
D53311	D43311	716	Alum	SST	TF	TF	D05311
D53315	D43315	716	Alum	SST	TF	HY	D05315
D53331	D43331	716	Alum	SST	SST	TF	D05331
D53335	D43335	716	Alum	SST	SST	HY	D05335
D53336	D43336	716	Alum	SST	SST	SP	D05336
D53337	D43337	716	Alum	SST	SST	BN	D05337
D53338	D43338	716	Alum	SST	SST	VT	D05338
D53355	D43355	716	Alum	SST	HY	HY	D05355
D53366	D43366	716	Alum	SST	SP	SP	D05366
D53377	D43377	716	Alum	SST	BN	BN	D05377
D53388	D43388	716	Alum	SST	VT	VT	D05388
D53911	D43911	716	Alum	PP	TF	TF	D05911
D53955	D43955	716	Alum	PP	HY	HY	D05955
D53966	D43966	716	Alum	PP	SP	SP	D05966
D53977	D43977	716	Alum	PP	BN	BN	D05977
D53D05	D43D05	716	Alum	Duckbill	None	HY	D05D05
D53D06	D43D06	716	Alum	Duckbill	None	SP	D05D06
D53D07	D43D07	716	Alum	Duckbill	None	BN	D05D07
D54211	D44211	716	316 SST	Acetal	TF	TF	D05211
D54231	D44231	716	316 SST	Acetal	SST	TF	D05231
D54311	D44311	716	316 SST	SST	TF	TF	D05311
D54331	D44331	716	316 SST	SST	SST	TF	D05331
D54335	D44335	716	316 SST	SST	SST	HY	D05335
D54336	D44336	716	316 SST	SST	SST	SP	D05336
D54377	D44377	716	316 SST	SST	BN	BN	D05377
D54381	D44381	716	316 SST	SST	VT	TF	D05381
D54388	D44388	716	316 SST	SST	VT	VT	D05388
D54911	D44911	716	316 SST	PP	TF	TF	D05911

Key

Acetal = Acetal
 Alum = Aluminum
 BN = Buna-N
 HY = Hytrel
 KY = Kynar
 PP = Polypropylene
 SP = Santoprene
 TF = Teflon
 VT = Viton

Husky 515/716 Accessories

- 190246 Aluminum Manifold for Vertical Suction Port**
- 221169 Groundable Air Hose**
Max. working pressure: 300 psi (2.1 MPa, 21 bar).
1/2 in. ID x 10 ft. (3 m).
Coupled 1/2 npt(m) x 1/4 npt(m).
- 110146 Air Line Filter**
Max. working pressure: 300 psi (2.1 MPa, 21 bar).
1/4 npt(f). Reusable 20 micron filter with drain cock.
- 208536 Air Quick Connect Coupler** 1/4 npt(f)
- 169970 Air Quick Connect Nipple** 1/4 npt(m)
- 110147 Air Regulator** 1/4 npt(f) with cover

Groundable Fluid Hoses:

Max. working pressure: 500 psi (3.5 MPa, 35 bar). Nylon core, urethane cover, 3/4 in. ID, 3/4 npt(mbe) and SST fittings.

- 221170** 3 ft. (0.9 m)
221171 6 ft. (1.8 m)
221172 10 ft. (3.0 m)
221173 25 ft. (7.6 m)

- 110134 Fluid Pressure Relief Valve**
Venting pressure: 150 psi (1.05 MPa, 10.5 bar)
- 222011 Grounding Wire and Clamp**
Length: 25 ft. (7.6 m). 12 ga. (1.5 mm²)
- 224835 Wall Mounting Bracket**
- 195264 CycleFlo Batch Controller**
Programmable batch controller for solenoid-operated (D4xxxx) pumps. Controls cycle rate and number of strokes.
- 195265 CycleFlo II Cycle Controller**
Adjusts cycle rate only. For use with solenoid-operated pumps.

Surge Suppressors

Automatic Models

Polypropylene wetted bottom housing and non-wetted top housing
Weight: 9 lbs. (4.1 kg)

- 239096** with Buna-N bladder
239121 with Teflon® bellows
239122 with Viton® bladder

SST wetted bottom housing and non-wetted top housing
Weight: 16 lbs. (7.3 kg)

- 239095** with Buna-N bladder
239123 with Teflon® bellows
239124 with Viton® bladder

Acetal wetted bottom housing and non-wetted top housing
Weight: 9 lbs. (4.1 kg)

- 239094** with Buna-N bladder
239125 with Teflon® bellows

Adjustable Models

Polypropylene wetted bottom housing and non-wetted top housing
Weight: 9 lbs. (4.1 kg)

- 239091** with Buna-N bladder
239129 with Teflon® bellows
239130 with Viton® bladder

SST wetted bottom housing and non-wetted top housing
Weight: 16 lbs. (7.3 kg)

- 239090** with Buna-N bladder
239131 with Teflon® bellows
239132 with Viton® bladder

Acetal wetted bottom housing and non-wetted top housing
Weight: 9 lbs. (4.1 kg)

- 239089** with Buna-N bladder
239133 with Teflon® bellows

Aluminum wetted bottom housing and non-wetted top housing
Weight: 9 lbs. (4.1 kg)

- 224892** with Teflon® bellows
224893 with Buna-N bladder

SST wetted bottom housing and aluminum non-wetted top housing
Weight: 16 lbs. (7.3 kg)

- 224894** with Teflon® bellows
224895 with Buna-N bladder

Sales/Distribution

North America Toll Free 877-84-GRACO (877-844-7226)
Telephone 612-623-6743
Fax 612-623-6580
www.graco.com

Locate authorized North American distributors
Product information literature



GRACO INC.
P.O. Box 1441
Minneapolis, MN 55440-1441



Graco Inc. is registered to I.S. EN ISO 9001.

All information, specifications, photographs, and illustrations contained in this document reflect the latest available information at publication time. Graco reserves the right to make changes at any time without notice.